

DIP

Decentralized Intelligent Peripheral

The DIP is an intelligent, decentralized peripheral device capable of autonomous operation in a small, compact housing for mounting to a top-hat rail with low installation depth. It can be used, independently of a PC, for measurement and control purposes.

In order to adapt it to particular applications the device may be fitted with X-Bus modules. Up to 2 modules can be stacked at each module slot. Connection to the peripheral is implemented via a total of 128 screw terminals. The function of these connections is provided by the modules that are used.

A communication interface connecting to a host permits application-related software to be downloaded and data to be exchanged with the host system. If the host interface is designed as a PROFIBUS-DP interface, the DIP can be applied as a device within a PROFIBUS-DP system. CAN and Ethernet are also possible.

The device is partitioned into a terminal block and an electronic block. The electronic block contains all the system's electronic circuitry. It is plugged into the terminal block. The terminal block carries the fixed wiring. It does not contain any electrical components that affect the function, so that the probability of failure is very low. No wires have to be disconnected when the electronic block is changed. The terminal block can be mounted on flat surfaces as well as on a standard profile rail.

Up to 48 input and output line states can be indicated by means of LEDs.

The DIP must be provided with a DC supply voltage of approx. 24V (18.6V to 36V). All the operating voltages required internally are generated from this, with galvanic isolation. A switch allows the device to be switched on and off.

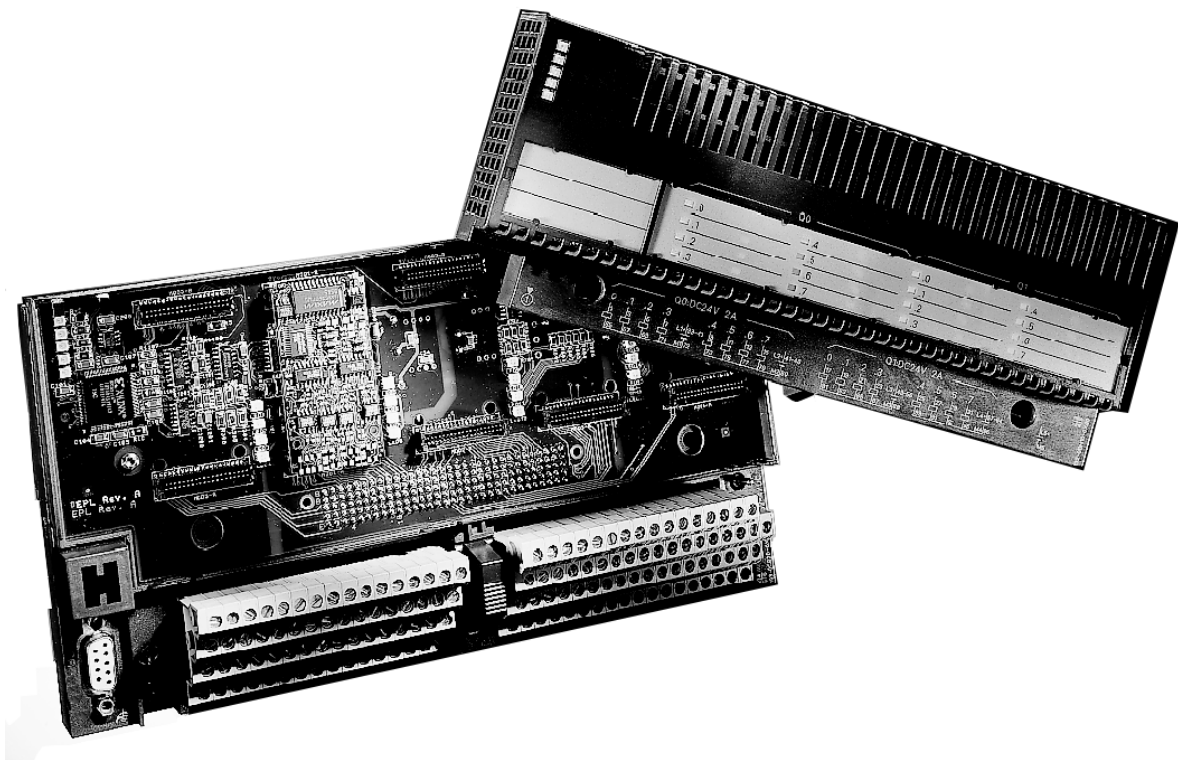

Special Features

- X-Bus CPU module X-MAX-1 to run application-related programs for measurement and control.
- 3 slots for any other X-Bus I/O modules.
- A total of 128 screw terminals for the connection of I/O signals. The particular function depends on what I/O modules are inserted.
- Host interface for downloading programs, and for data exchange or for connection to a fieldbus system such as PROFIBUS-DP or CAN.
- By exchanging the modules and the associated software it is easy to adapt the device for a variety of tasks.

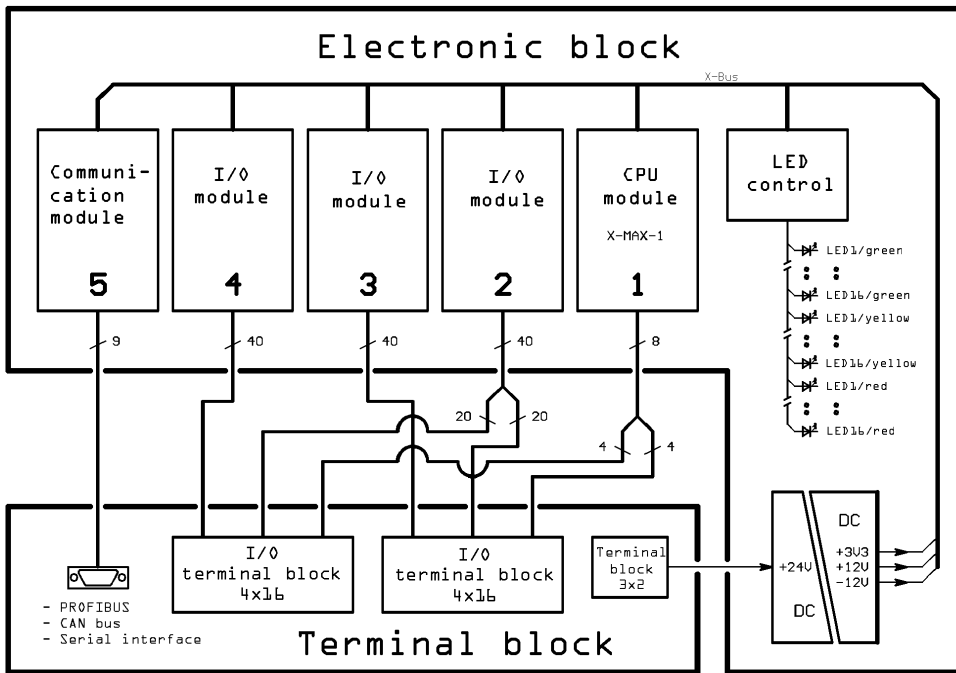

- Up to 2 modules can be stacked at each slot.
- 16 three-colour LEDs to indicate signal states.
- Supply voltage: 24V
- Partition into terminal and electronic blocks. This permits exchange of the electronics without disconnecting the electrical connections to the peripherals.
- Can be mounted on a DIN rail or on a flat surface.

Applicable X-Bus Modules

The device has a total of 5 slots where X-Bus modules may be inserted. Modules can be inserted as described in this table.

The assignments of slots 1 and 5 is fixed. This means that those slots can only be used for modules of the given type and for associated modules. Two modules can be stacked in each slot.

Slot no.	Possible modules	Function	Explanation
1	X-MAX-1/33 X-MAX-1/100	CPU module	Slot 1 <i>must</i> be fitted with at least one processor module.
2 3 4	Any X-Bus I/O module	User I/O	The "A" connectors of these module slots are accessible via screw terminals. There are 40 connections for each slot.
5	X-DPS-12 X-COM-2 X-CAN-2	Host interface	The host interface is taken to a 9-pin sub-D socket. This can be used directly for a PROFIBUS-DP connection. A gender changer must be inserted in between for a serial interface or for CAN bus.

Technical Data

Parameter	Symbol	Conditions	Min.	Typ.	Max.	Unit	Information
Supply voltage	U_v		18.6	24	36	V	
Current consumption at full load	I_v	at $U_v=18.6V$, modules inserted			1.4	A	
Galvanic isolation				500		V	
Ambient temperature	T_A		0	20	40	°C	
Cross-section of connecting cable	A_A		0.5		1.5	mm ²	PE conductor up to 2.5 mm ²
Dimensions		Terminal block + electronic block		235 130 60		mm	Width Height Depth

Host Interface Pin Assignments

The device has a 9-pin sub-D connector for the host interface. The sub-D socket in the standard implementation can be used directly for PROFIBUS-DP. For an interface to the CAN bus or a serial interface, a gender changer, male on both sides, must be inserted.

The pin assignment of this connector is described in the following table, in accordance with the communication module in use. It should be noted that serial interfaces may also be operated in various modes, and some signals can have differing functions (see also the data sheet for the communication module being used).

Pin no.	PROFIBUS-DP	CAN bus ^{<1>}	Serial interface RS-232 ^{<1>}	Serial interface RS-422 ^{<1>}	Serial interface RS-485 ^{<1>}
1	DPPE	–	DCD	RTS– CLK _{OUT} –	RTS–
2	–	CAN_L	RxD	CTS– CLK _{IN} –	CTS–
3	DPB	CAN_GND	TxD	TMT–	TMT–
4	DPRTS	–	DTR	RCV–	RCV–
5	DPGND	CAN_GND	GND	GND	GROUND
6	DP5V	CAN_GND	DSR	RTS+ CLK _{OUT} +	RTS+ CLK _{OUT}
7	–	CAN_H	RTS CLK _{OUT}	CTS+ CLK _{IN} +	CTS+ CLK _{IN}
8	DPA	–	CTS CLK _{IN}	TMT+	TMT+
9	–	CAN_V5 ^{<2>}	RI	RCV+	RCV+

<1> with gender changer inserted

<2> optional

Signal Assignments for the Screw Terminal Blocks

The following table lists the connections of the I/O lines at the module slots to the screw terminals.

The connections are identified as illustrated by the following examples:

- S2A23 = Slot 2, pin A23
 The actual function of the connection concerned depends on which X-Bus module is plugged into the slot, and can be found in the relevant data sheet.
- L+ = 24V supply voltage
- 0 V = Reference voltage for the supply
- PE = Protective earth connection

		L+		0V		PE	
		L+		0V		PE	
32	S1A8	64	S1A7	96	S1A6	128	S1A5
31	S2A40	63	S2A39	95	S2A38	127	S2A37
30	S2A36	62	S2A35	94	S2A34	126	S2A33
29	S2A32	61	S2A31	93	S2A30	125	S2A29
28	S2A28	60	S2A27	92	S2A26	124	S2A25
27	S2A24	59	S2A23	91	S2A22	123	S2A21
26	S3A40	58	S3A39	90	S3A38	122	S3A37
25	S3A36	57	S3A35	89	S3A34	121	S3A33
24	S3A32	56	S3A31	88	S3A30	120	S3A29
23	S3A28	55	S3A27	87	S3A26	119	S3A25
22	S3A24	54	S3A23	86	S3A22	118	S3A21
21	S3A20	53	S3A19	85	S3A18	117	S3A17
20	S3A16	52	S3A15	84	S3A14	116	S3A13
19	S3A12	51	S3A11	83	S3A10	115	S3A9
18	S3A8	50	S3A7	82	S3A6	114	S3A5
17	S3A4	49	S3A3	81	S3A2	113	S3A1

↑ right hand section of terminal block ↑

↓ left hand section of terminal block ↓

16	S1A4	48	S1A3	80	S1A2	112	S1A1
15	S2A20	47	S2A19	79	S2A18	111	S2A17
14	S2A16	46	S2A15	78	S2A14	110	S2A13
13	S2A12	45	S2A11	77	S2A10	109	S2A9
12	S2A8	44	S2A7	76	S2A6	108	S2A5
11	S2A4	43	S2A3	75	S2A2	107	S2A1
10	S4A40	42	S4A39	74	S4A38	106	S4A37
9	S4A36	41	S4A35	73	S4A34	105	S4A33
8	S4A32	40	S4A31	72	S4A30	104	S4A29
7	S4A28	39	S4A27	71	S4A26	103	S4A25
6	S4A24	38	S4A23	70	S4A22	102	S4A21
5	S4A20	37	S4A19	69	S4A18	101	S4A17
4	S4A16	36	S4A15	68	S4A14	100	S4A13
3	S4A12	35	S4A11	67	S4A10	99	S4A9
2	S4A8	34	S4A7	66	S4A6	98	S4A5
1	S4A4	33	S4A3	65	S4A2	97	S4A1