

MAX-Box

A stand alone system for intelligent SORCUS cards

The SORCUS MAX-Box enables intelligent SORCUS PC plug-in cards to be operated outside a PC as an independent, intelligent system.

The system has the same dimensions and connectors as a 5¼" hard disk, and can be mounted in the same way.

The power supply is provided by single DC voltage. The system can also be operated via a mains adapter on a 230V supply. All the voltages required on the installed card are created and monitored in the MAX-Box with galvanic isolation.

The actual payload of the MAX-Box is usually an intelligent SORCUS card such as, for example a "small" MODULAR-4/486 with 2 SP-Bus module slots, or a Multi-COM card. The MAX6isa X-Bus multiprocessor card can also be used.

The I/O connections of the carrier board card are taken to the front via sub-D connectors with a total of up to 124 connections.

Connection to a host computer is via a serial interface which is provided on all intelligent SORCUS cards. It can be adapted to the desired physical interface by means of a small plug-in module in the MAX-Box, known as an S-Link, e.g. to RS-232, RS-422, RS-485, 20 mA or CAN.

The host PC communicates with the stand-alone card with the aid of function libraries. The programming is not different from that of a SORCUS card that is inserted directly into the PC.

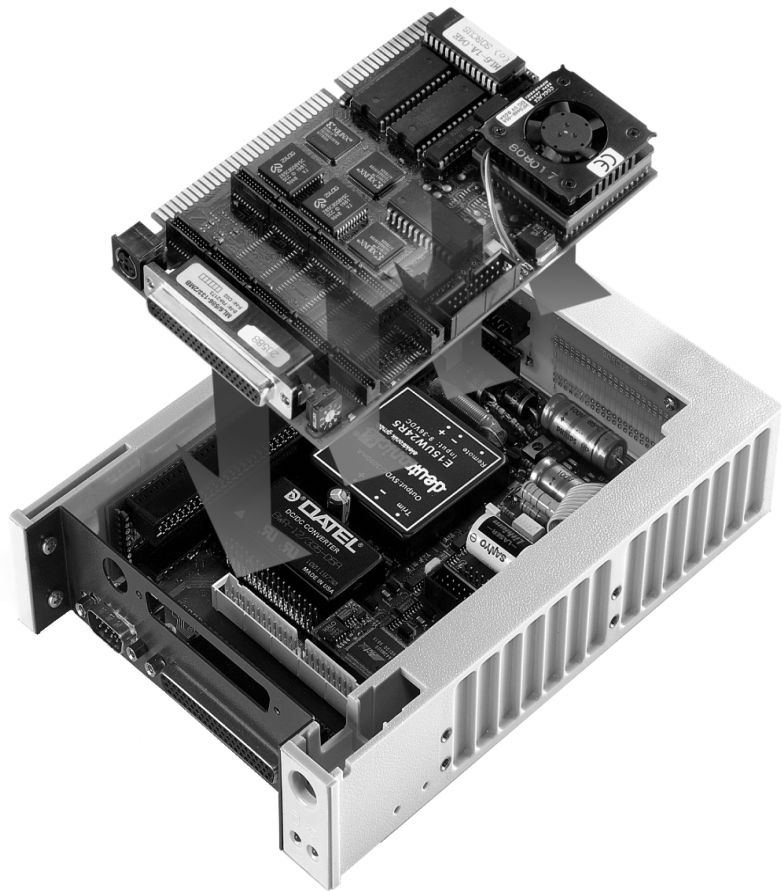

Block diagram with a "small" MODULAR-4/486 as payload

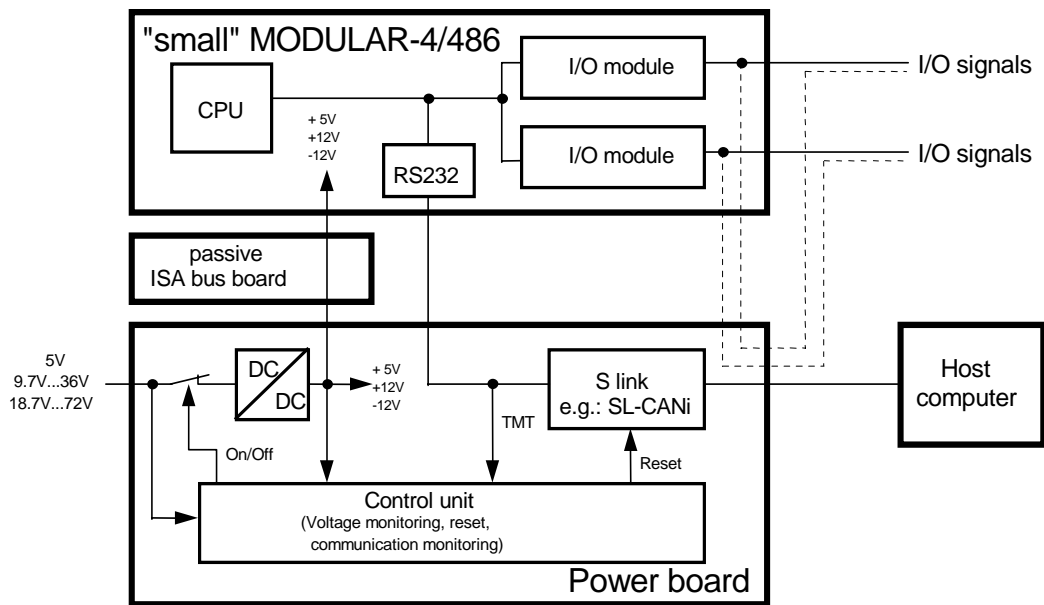

Structure

The MAX-Box consists of the following components:

- 5¼" frame: An assembly frame carries all the electronic components. Its dimensions correspond to those of a 5¼" PC module, and it can be fitted in the same way. It can also be mounted in a desktop or mounting box such as are available for CD-ROM drives.
- Power board: The power board contains all the components necessary to permit stand-alone operation to the intelligent PC card. This involves primarily the power supply and the physical connection to the host via an S-Link.
- Passive ISA bus board: This board connects the power supply from the power board through to the PC card.
- Usable PC cards:
 - "small" MODULAR-4/486
 - Multi-COM
 - MAX6isa with X-MAX-1

Power Supplies and Possible Application Areas

The MAX-Box is powered from a single DC voltage. There are three versions of the power supply system, identified as A, B and C in this table. They are only distinguished by the voltage range of the supplied power (see also technical data).

The examples of possible application areas in the table result from the differing power supplies.

If AC mains is all that is available at the location of an application, a suitable external power supply unit can be used to generate an appropriate DC voltage to operate the system.

Application areas	Supply voltage	Applicable versions
Desk top device	Depending on version	A, B, C
PC (5¼" slot)	5V (5V..7V)	A
Motor vehicle	12V (9.7V...36V)	B
	42V (18.7V...72V)	C
Industry, goods vehicles, marine	24V (9.7V...36V)	B
	(18.7V...72V)	C
Aeroplane	48V (18.7V...72V)	C

The supply voltage is monitored in order to protect the MAX-Box against excessive voltage. If the level of the supply voltage is larger than the permitted maximum for the particular version, the system is automatically isolated from the supply voltage.

Usable Intelligent PC Cards

The MAX-Box can be adapted to the requirements of a particular application through the selection of the card and of the I/O modules with which it is fitted. The interface connectors are located at the front. At the rear there is only one connector for connection of the supply voltage. The following interfaces may be available at the front of the MAX-Box, depending on the PC card in use:

PC card	Interface	Purpose	Information
Multi-COM	62-pin sub-D connector	User I/O	5 serial interfaces, physically configurable with S-Links (see Multi-COM manual)
	Mini-DIN socket	User I/O	Serial interface (RS232)
	9-pin sub-D connector	Host I/O	For program download and data exchange between the host computer and the MAX-Box. Physically adaptable to the following with S-Link on the power board: RS-232, RS-422, RS-485, 20mA, CAN-bus, PROFIBUS-DP.
"small" MODULAR-4/486	2 x 9-pin sub-D connectors and/or 62-pin sub-D connector	User I/O	Connector directly on the inserted SPB modules. Pin assignment depends on the module type. Can be used to substitute for connectors that are not available on the modules themselves. Pin assignment depends on the type of the SPB module.
	9-pin sub-D connector	Host I/O	For program download and data exchange between the host computer and the MAX-Box. Physically adaptable to the following with S-Link on the power board: RS-232, RS-422, RS-485, 20mA, CAN-bus, PROFIBUS-DP.
MAX6isa with X-MAX-1	2 x 62-pin sub-D connectors	User I/O	Pin assignment depends on the X-Bus modules fitted.
	9-pin sub-D connector	Host I/O	For program download and data exchange between the host computer and the MAX-Box. Physically adaptable to the following with S-Link on the power board: RS-232, RS-422, RS-485, 20mA, CAN-bus, PROFIBUS-DP.

Status Displays

A red and a green LED on the front provide information about the status of the system.

Possible states and their significance are explained in the table.

LED		System status
Red	Green	
off	lit	All operating voltages present.
lit	lit	Although operating voltages are present, the system is not ready to operate. Communication between the host computer and the MAX-Box has not been established.
off	off	The device is not ready to operate. The supply voltage is absent or is too low.

Host Connection

Connection to the host computer is usually implemented via a serial interface which is a standard feature of the intelligent PC card. It is physically configured by an S-Link plugged onto the power board. The S-Links listed in this table can be used.

A 9-pin sub-D connector is available for the connection to the host computer.

Physical interface	Usable S-Links	Explanation
RS-232	SL-232S	RS-232
	SL-232i	RS-232 isolated
RS-422	SL-422S	RS-422
	SL-422i	RS-422 isolated
RS-485	SL-485S	RS-485
	SL-485i	RS-485 isolated
20mA	SL-20MA	20mA Current loop
CAN	SL-CANi	for CAN Bus, corresponding specification 2.0A and 2.0B, isolated
PROFIBUS-DP	SL-DPSi	for PROFIBUS-DP slave connection, isolated

Technical Data

This data refers to a MAX-Box without an intelligent PC card. The data in the associated data sheets applies to the Multi-COM, "small" MODULAR-4/486 and the MAX6isa.

Parameter	Min.	Typ.	Max.	Unit	Version	Comment
Supply voltage	4.8	5	7	V	A	
	9.7	12 24	36		B	
	18.7	24 48	72		C	
Switch-off threshold		5.5		V	A	With rising supply voltage.
		37			B	
		73			C	
Operating temperature	0	25	60	°C	All	
Dimensions	-	149	-	mm	All	Width
	-	42	-			Height
	-	190	-			Depth

Power Supply Connector Pin-Out

The connector for the supply voltage is located at the rear of the system. It is a 4-pin connector of the type typically used for supplying power to PC components.

